



# Seeding



You can find the current status of the certified functionalities\* in the AEF database.

# Table of contents

Function overview	Page	3
ISOBUS PLANTER-Controller	Page	4
ISOBUS DRILL-Controller	Page	6
AIRidium®	Page	8
PLANTirium®	Page	9
ME-Configurator	Seite	10
DRILL-Control	Page	12
DRILLMAT III	Page	14
PRECIMAT	Page	15

All information about the company and the products can be found here:



[www.mueller-elektronik.de](http://www.mueller-elektronik.de)



[shop.mueller-elektronik.de](http://shop.mueller-elektronik.de)



[www.facebook.com/me.salzkotten](https://www.facebook.com/me.salzkotten)

## Function Overview

Function Overview	ISOBUS PLANTER-Controller
<b>Number of metering units</b>	1 to 12 via PWM 1 to 72 via MRC module
<b>Pre-metering</b>	on the work screen/ AUX-N joystick
<b>Half width shutoff system</b>	x
<b>Target rate adjustment</b>	x
<b>Fan</b>	control up to 2 or monitoring
<b>Tramline</b>	ERC / MRC / ECU MIDI 3.0
<b>Fill level sensor</b>	1 to 100
<b>Pre-emergence marker</b>	–
<b>Blockage monitoring</b>	up to 44 rows via ECU MIDI 3.0 up to 56 rows via ERC-Modul up to 128 rows via Monitoring module up to 64 rows via Control module
<b>Internal task counter</b>	x
<b>Product database</b>	x
<b>Folding</b>	x
<b>Lifting/Lowering</b>	x
<b>ISOBUS</b>	x
<b>ISOBUS-TC</b>	x
<b>SECTION-Control</b>	x
<b>MULTI-Control</b>	x

AEF Certified

# ISOBUS

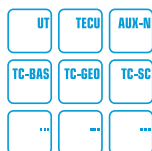

[www.aef-isobus-database.org](http://www.aef-isobus-database.org)

ME job computers comply with ISOBUS standard 11783 and are AEF-certified. You can find the current state of the certified functionalities\* in the AEF database.

\* subject to change

ISOBUS DRILL-Controller	DRILL-Control	DRILLMAT III	PRECIMAT
1 to 12	1	-	-
on the work screen/ AUX-N joystick	on the work screen	-	-
x	-	-	-
x	x	-	-
control up to 2 or monitoring	1 monitoring	1 monitoring	1
Motor, solenoid (L&R)	Motor, solenoid (L&R)	Motor,	-
1 to 100	1 to 2	1	-
Solenoid (L&R)	Solenoid (L&R)	Solenoid	-
Agtron Dickey John	-	-	Without shut-off up to 18 rows With shut-off up to 12 rows
x	x	-	x
x	x	-	-
x	-	-	-
x	-	-	-
x	via ASD	-	-
x	via ASD	-	-
x	-	-	-

# ISOBUS PLANTER-Controller

The ISOBUS PLANTER-Controller is a control system for implements with mechanical, central or single drive. The job computer regulates the spread rate according to the set target rate in seeds per hectare. Both electric and hydraulic motors can be actuated to regulate the rate. Using sensor technology (e.g. optosensors or the newly developed PLANTirium® sensor), the seed is counted and monitored on each row. In addition, different shut-off clutches can be switched manually or automatically (SECTION-Control) for each metering unit. The motor control of the seed rate per row allows the optimum seed placement and holds a great savings potential. On more complex implements with supplemental fertiliser placement, the system can also regulate this target rate according to specifications.

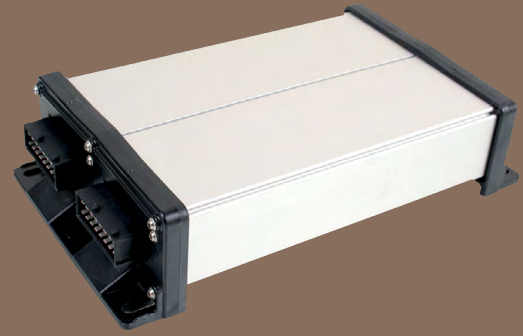

## Functions

The ISOBUS PLANTER-Controller can be individually configured for virtually any precision planter functionality. These configurations can be adjusted either using a PC configurator or directly on the terminal.

In addition, you can use the ISOBUS-Joystick or the ISOBUS-Joystick PRO to operate. Through the support of AUX-N functionalities, the tractor driving lever can also be used to control the implement.

The PLANTER-Controller offers internal trip and total counters for the area, quantity, time and area output for documentation purposes.

Manufacturer-specific hydraulic functions for controlling the bout marker, folding and similar can be integrated as well as the working lights.

## Other functions

- Tramline control
  - The system automatically calculates the rhythm
  - Only the working width, number of rows and beginning side of the field must be entered
- Detection of the working position via switch, angle sensor or CAN
- Integrated product database for up to 30 products (seed and fertiliser)
  - The calibration results are saved along with the product
  - Speed, target rate and calibration factor
- Monitoring of metering shafts
- Control of up to two fans or pressure sensors
- Fill level sensors in the fertiliser hopper

## Advantages

- AEF-certified ISOBUS system
- Configurable software
- MULTI-Control
- OEM adjustments possible

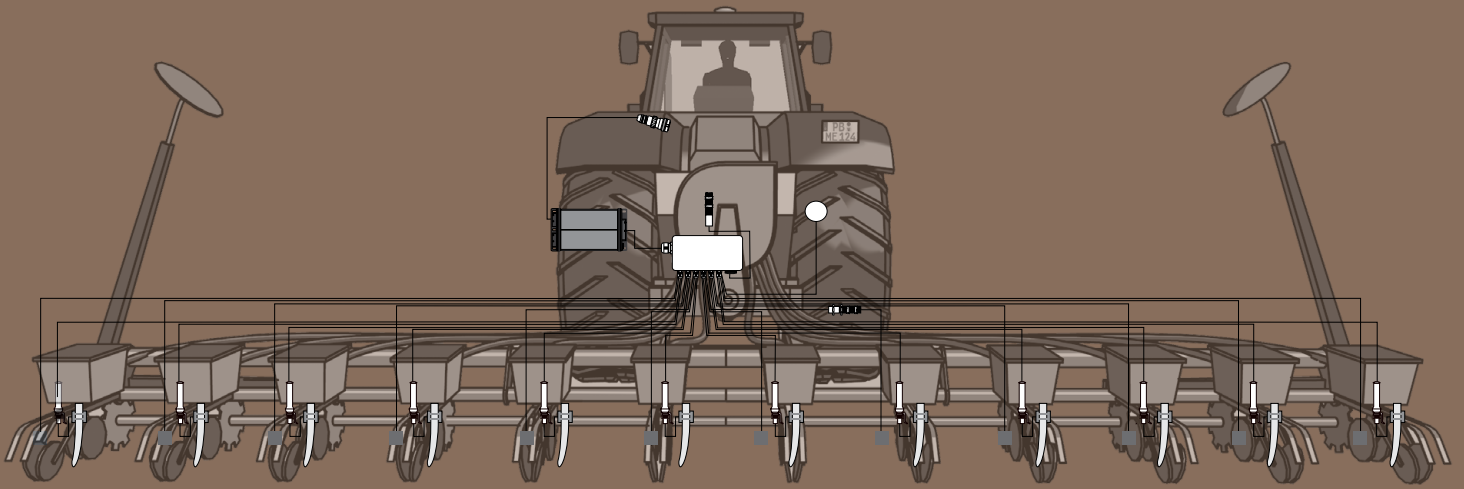

With the clear layout of the user interface, all of the functions are easily and rapidly accessible by pressing a few buttons. The functions are called up using intuitively designed graphic softkeys. A clear arrangement of the functions also facilitates orientation within the software.

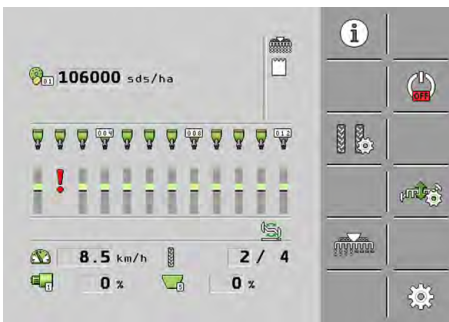

#### Profile of a mechanical precision planter

- Display of the seeding precision with bar graphs for each seeding unit
- Display of the tramline rhythm and deactivated rows
- Display of the current rate in seeds per hectare



Display of implement counters



Setting the tramline rhythm



Manual switching on and off of the seeding units

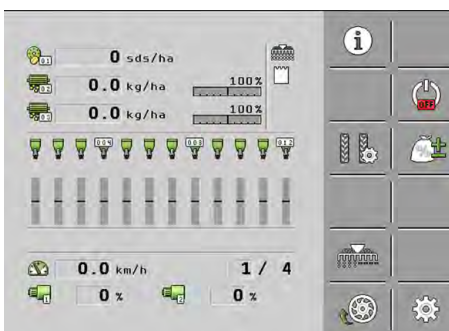

#### Profile of a precision planter with fertiliser metering

- Display of the fan speed
- Display of the current rate for the fertiliser metering



Pre-metering



General settings and calibration



Adjustment of the target rate

# ISOBUS DRILL-Controller

The ISOBUS DRILL-Controller is a control system for implements with up to 4 metering drives. The job computer regulates, monitors and controls all of the connected components of a seeder. The spread rate is regulated according to the set target rates for each metering unit with up to six different products (seed and fertiliser). Both electric and hydraulic motors can be used to achieve regulation. For implements with extensive equipment, the system is expanded with an additional job computer. This solution is therefore ideal for all manufacturers, from the simple one-hopper implement all the way to complex large-scale implements with simultaneous spreading of fertiliser and seed.

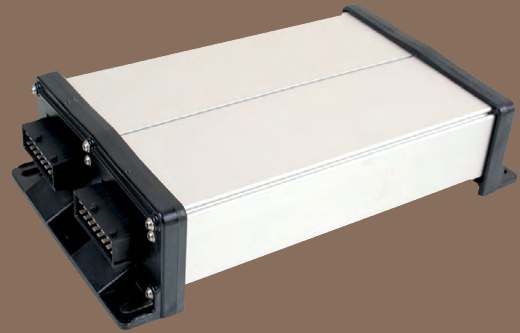

## Functions

With its individual configuration options, the ISOBUS DRILL-Controller for seeders can be adapted to virtually any seeder functionality. The configurations can be created and edited either using a PC configurator or directly on the terminal. In addition to the regulation of the metering drives, the scope of functions also includes the monitoring of up to four metering shafts as well as the fan speed. Corresponding fill level sensors can also be installed on each seed hopper.

The clear menu navigation makes calibration easier. After entering the target rate, the calibration can be started. The calibration weight is then entered and the system is automatically calibrated. In the integrated product database, the calibration results for up to 30 types of seed or fertiliser can be saved with the corresponding values such as min./max. working speed, target rate and calibration factor. Special software functions, e.g. the waterhole mode or obstacle mode, considerably reduce the operator's workload. Pre-metering enables precise seeding especially on the field's headlands.

In addition, you can use the ISOBUS-Joystick or the ISOBUS-Joystick PRO to operate. Through the support of AUX-N functionalities, the tractor driving lever can also be used to control the implement. The DRILL-Controller offers internal trip and total counters for the area, quantity, time and area output for documentation purposes. Manufacturer-specific hydraulic functions for controlling the bout marker, folding and similar can be integrated as well as the working lights.

## Other functions

- pre-programmed tramline rhythms and the option of storing individual rhythms
- Option of using solenoid or motorized tramline valves
- Control of a pre-emergence marker
- Recording of the working speed via CAN-BUS or directly on the implement via sensors
- A speed can be simulated for servicing purposes
- Half width shutoff system via control of the linear actuator or switching off the metering drives
- Control of work lights, hopper lights and beacon
- Display of residual volume, area, and distance

## Advantages

- AEF-certified ISOBUS system
- Configurable software
- MULTI-Control
- OEM adjustments possible

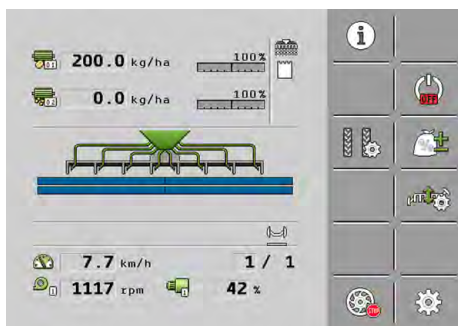
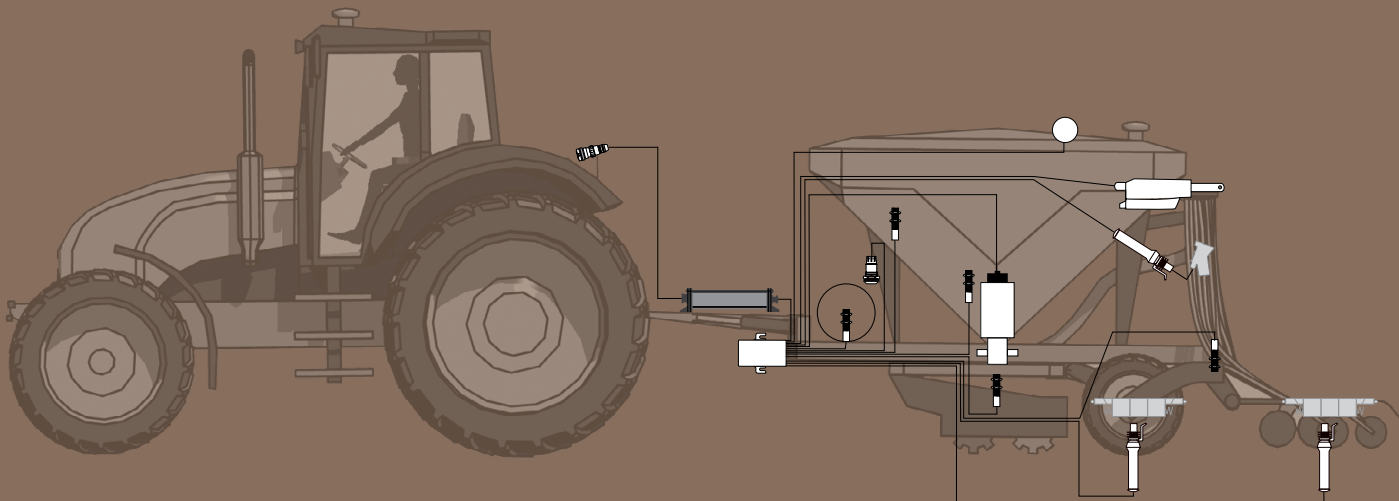

### Profile of a seeder with two metering units for seed and fertiliser

- Display of the current rate for both products
- Display of the tramline rhythm
- Status display for SECTION-Control and for ISOBUSTASK-Control



Starting/stopping the system



General settings and calibration



Screen for target rate adjustment

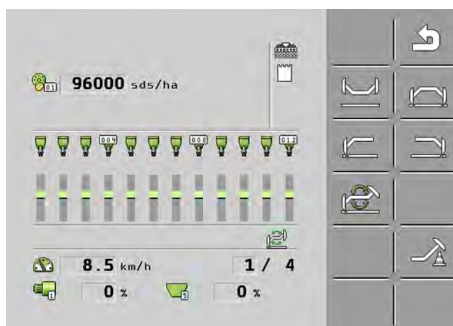

### Screen during hydraulic control

- Display of the bout marker status
- Display of the fan speed



Automatic bout marker mode



Obstacle mode



Both bout markers down

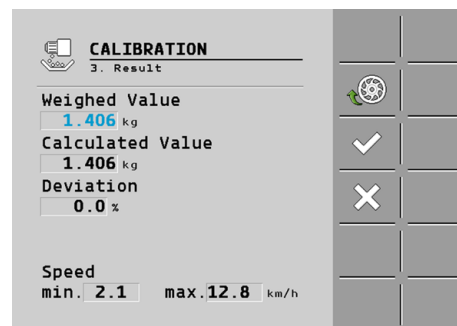

### Screen after the calibration

- Entry of the weighed value
- The system calculates the deviation between the weighed and calculated value
- Display of the min./max. working speed

## AlRidium®

AlRidium® is a newly developed measuring system for seed-precise blockage monitoring of different seeds in pneumatic seeders. This sensor therefore enables seeding without calibration for the first time.

The patented Piezo sensor technology compels with high measurement accuracy and sturdiness. The system comprises both sensors and a master control unit (ECU), which performs the evaluation. In addition to the precise counting of large seeds such as peas and corn, fine seeds like rapeseed can be detected under the most difficult conditions (vibrations and dust). In contrast, optosensors get dirty very fast and must be cleaned regularly.

Thanks to the high counting precision, blockages are detected more rapidly and reliably. AlRidium® allows the calibration factor to be determined many times per second. Even under changing environmental conditions, the correct number of seeds can be planted to finally achieve more uniform crops.



OEM-specific adaptation required

### Properties

- Counting speed of 1 to 10,000 seeds/second
- Robust sensor design, resistant to vibrations and shocks
- Self-cleaning effect
- Filtering of dust and debris
- Software update possible on the field
- Measuring system can be customised to OEM specifications

### Fields of application

- Seeding without calibration, only the seeds/m<sup>2</sup> must be entered
- Monitoring of the seed flow and notification in case of blockage
- Lateral distribution monitoring
- Longitudinal distribution monitoring

### Advantages

- Calibration no longer required
- Grain-precise detection of the seed
- Blockage monitoring
- Determination of the lateral and longitudinal distribution

### Automatic row shutoff system

As an option, the ECU can be extended with one tramline flap control for up to 100 % of the rows. For the first time, this allows all different tramline rhythms and widths to be flexibly controlled per GPS.

With SECTION-Control, each row on the headland can be individually controlled.

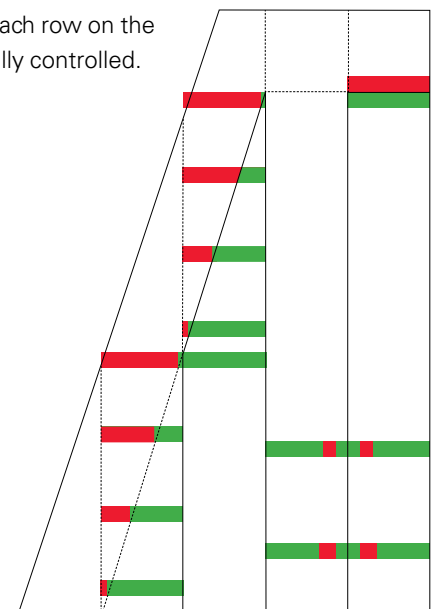

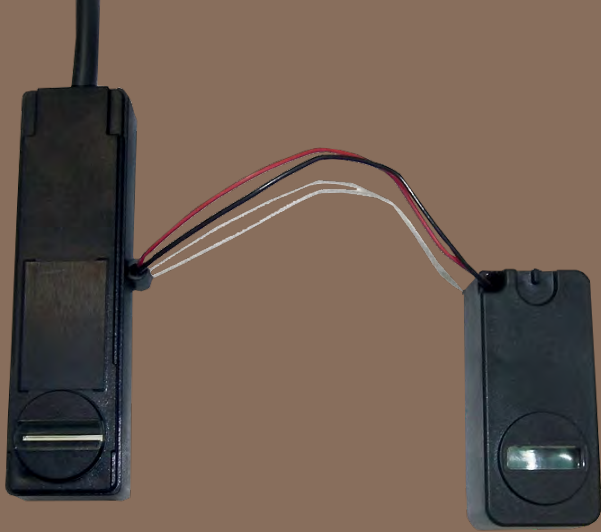

## PLANTirium®

The PLANTirium® sensor is the first seed tube sensor capable of detecting objects using imaging sensor technology while offering an interface for parametrisation, status indication and software updates. Imaging sensor technology enables the detection of small seeds (rapeseed) or larger seeds (corn or sunflower seeds) even in difficult conditions. A pattern recognition method is used to distinguish debris from seeds inside the seed tube. Also, the sensor recognises overlapping seeds as multiples. Active sensor re-adjustment provides reliable compensation for debris accumulating on the sensor.

Through the one-wire interface, the sensor can always be kept up-to-date using the software update function. Parametrisation ensures that the sensor is always optimally adjusted to the current seed and that the system can automatically adapt to new seed types. The PLANTirium® sensor also uses this interface for active status indication. The user can therefore always rely on the displayed implement data, knowing that the values are not influenced by the sensor.

### Properties

- 1 to 150 seeds per second
- Seed speed of up to 12m/s
- Detects small seeds such as rapeseed or sugar beet as well as larger seeds such as corn, soy beans or sunflower seeds
- Automatically adapts to new seed types
- Detects multiples (overlapping seeds)
- Uniform illumination across the entire sensor width prevents shadowed areas
- Filters dust and debris, i.e. can be used even under extremely dusty conditions
- Compensates for dust, graphite or seed dressing build-up on the sensor
- Software update possible on the field
- Sensor status messages to the Master ECU (e.g. Cleaning required)
- Casing can be customised to OEM specifications
- Can also be integrated in control computers from other manufacturers



PLANTirium®-Sensor unit on the seed tube

### Advantages

- Image-generating sensor technology for seed detection
- Detection of gaps and multiples
- Automatically adapts to new seed patterns
- Automatic determination of the transmission power

## MRC module

The MRC module (Motor Row Control) is an add-on module for the job computer of the precision planter. This module is used to control electrically driven seeding units.

The MRC modules allow a precise seed spacing to be set for each individual row. This enables uniform seed spacing when driving in curves or offset seed placement in neighbouring rows (DeltaRow placement).

The blockage monitoring and calculation of statistical parameters for the placement accuracy are performed through evaluation by optical sensors.

Data exchange with the PLANTirium® sensor is possible through the integrated LIN interface. The master job computer of the planter can therefore communicate with the PLANTirium® sensor, e.g. to perform sensor diagnostics and sensor configurations.



### Functions

- Control of planter metering units powered by stepper motors
- Seed spacing is adjustable for each row by using prescription maps (VARIABLE RATE-Control)
- Communication with PLANTirium® sensors.

### Properties

- Seeding without calibration, only the seeds/m<sup>2</sup> must be entered
- Monitoring of the seed flow and notification in case of blockage
- Lateral distribution monitoring
- Longitudinal distribution monitoring
- Integrated drivers for up to 2 stepper motors
- Supports up to 2 seed tube sensors
- The supply voltage of the seed tube sensors can be switched between 8 and 12 V.
- Software update possible on the field
- Simple daisy-chain cabling

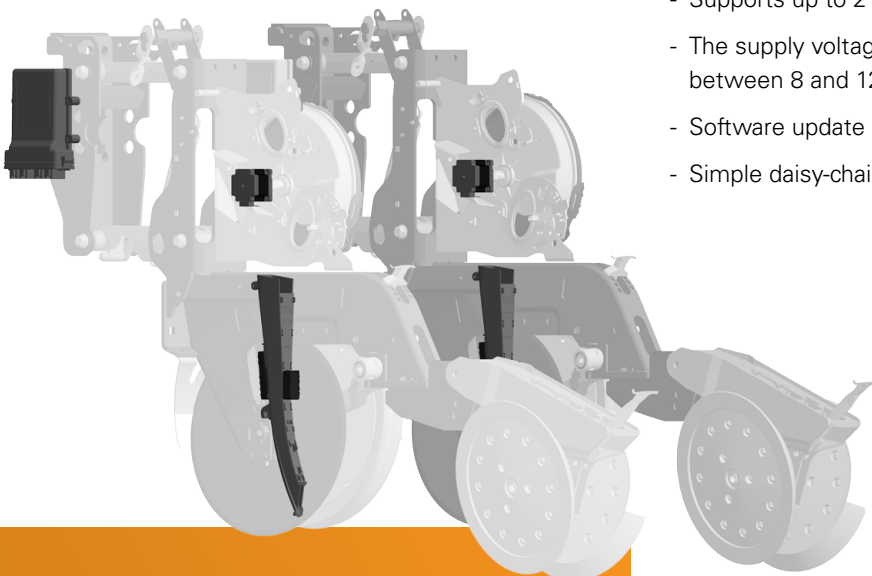

### Advantages

- Cascadable through modularity
- Individual seed spacing per row
- Turn compensation
- Supports Unterstützt PLANTirium®
- SECTION-Control

### Advantages of using a stepper motor:

- Easier synchronization of the rows
- No regulation needed
- Fixed specification of the current, no overload in case of blockages
- Smaller gear ratio necessary, stepper could also be operated directly on the disc
- The stepper adheres to the given steps

# ME Configurator for DRILL-/PLANTER-Controller

The ME-Configurator is a user-friendly software tool that is used to configure the scope of functions of a seeder or a planter. The clear and intuitive menu structure makes it easier for the user to set up the implement. Data exchange between the PC and job computer is bidirectional. Thus, it is possible to transfer a previously created configuration file from the PC to the job computer or to transfer it from a ME terminal to the job computer via a USB memory device. This simplifies e.g. the use in the end-of-line production. The configurator is also very practical for servicing. In this case, the functions can be edited directly on the implement.

## Assignment of the functions to the inputs/outputs

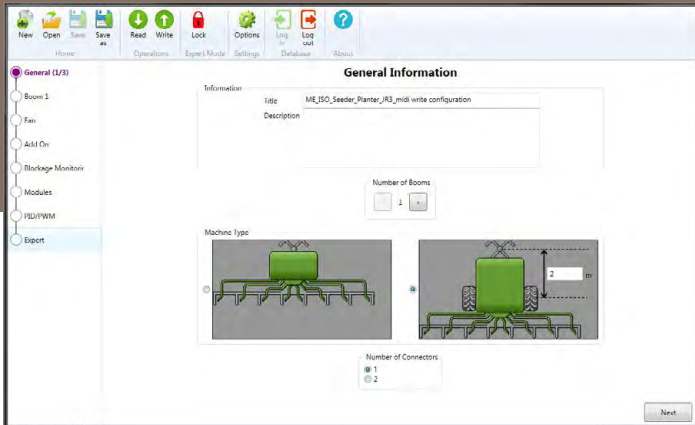

## Activating inputs/outputs

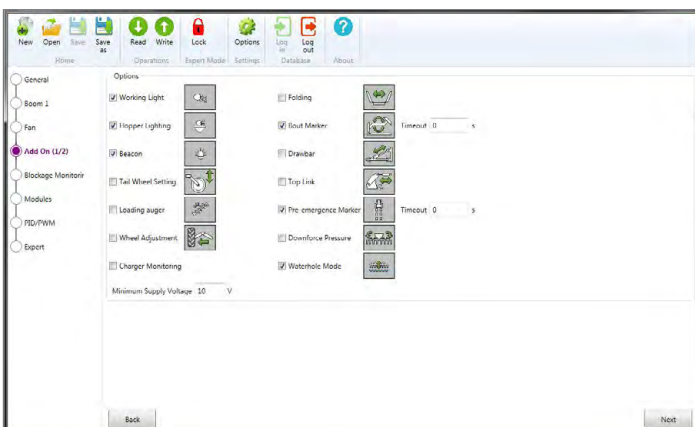

## Functions

In the respective menus, the implement functions can be selected and the corresponding inputs/outputs on the job computer can be activated. The assignment to specific hydraulic functions can be pre-defined.

With the simple menu structure, the user can create or adjust a configuration for virtually any seeder or precision planter after a short training period. All of the parameters that are already known, such as the pulses/100m, regulation data for the metering drives or the geometry, can be easily entered on the PC.

## Defining the implement parameters

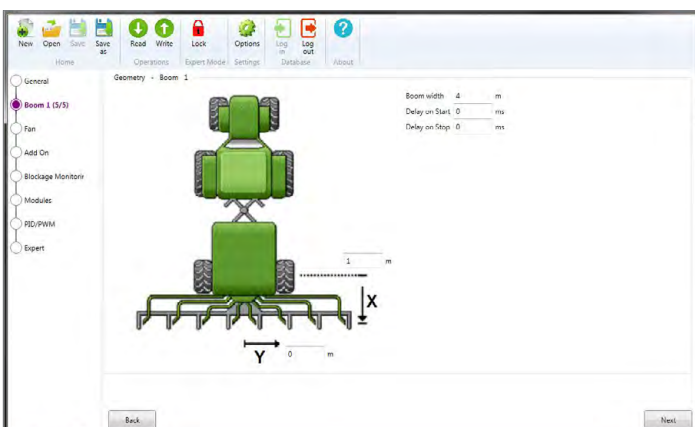

## Advantages

- Easier configuration for end-of-line production
- Comfortable use for service
- Always current due to regular updates

# DRILL-Control

The DRILL-Control is a closed control system for seeders for a product or a metering drive. The system regulates the spread rate according to the set target rates. An electric engine that is adapted for the system is used for regulation. This combination of display and controller is an easy entry-level solution for automating the seeder.



## Functions



With just a few configuration steps, DRILL-Control can be adapted to the required conditions. The configurations can be created and edited either using a PC configurator or directly on the terminal. For documentation purposes, the DRILL-Controller offers internal trip and total counters for the area, quantity, time and area output. The standardised ASD interface can be used to predefine and read out application rates. Moreover, the system then becomes compatible with SECTION-Control. As a standard, DRILL-Control is capable of controlling the bout marker and pre-emergence marker as well as monitoring the fan speed and the hopper fill level.

## Other functions

- Pre-programmed tramline rhythms for the seeder and the option of storing individual rhythms
- Integrated product database for up to 30 products (seed and fertiliser)
  - The calibration results are saved along with the product
  - Speed, target rate and calibration factor
- Control of solenoid or motorized tramline valves
- Starting the calibration using an external calibration button

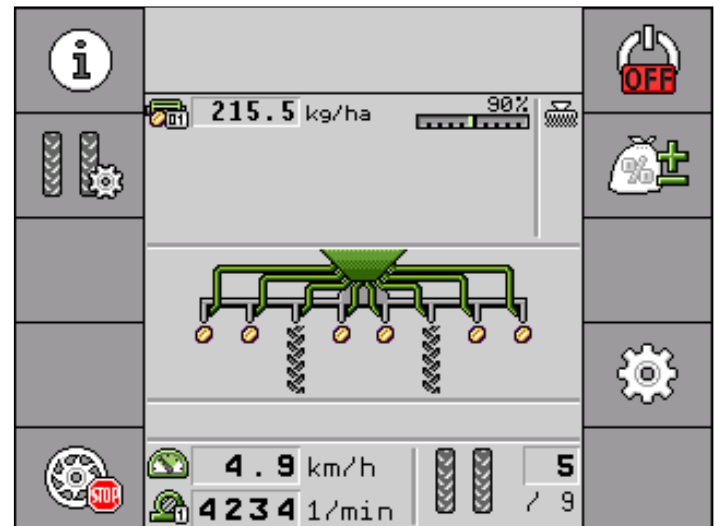
Screenshot of DRILL-Control during operation



-  Opens the results screens
-  General settings and calibration
-  Screen for target rate adjustment

## Advantages

- Easy handling
- Combined display and controller solution
- Inexpensive entry-level solution
- Available as a kit, including the electric metering drive



## SECTION-Control via ASD

DRILL-Control is equipped with a serial interface. This interface can be used to exchange both target rates and section statuses with other operating devices by means of the ASD protocol.

To do so, both devices (observe other requirements) must support the ASD protocol. DRILL-Control can therefore automatically adjust the seeding rate from a corresponding prescription map. To be able to use automatic section control, the SECTION-Control app must also be activated on the terminal.

## Advantages

- Inexpensive retrofitting of non-ISOBUS implements:
  - For using SECTION-Control
  - For using prescription maps
- Easy to operate
- Rapid installation
- Saving of resources

# DRILLMAT III

DRILLMAT III is used on seeders to automatically create tramlines. The variety of different pre-programmed rhythms allows for the combination of any seeder working width with the desired tramline distance.



## Functions

Seeding can begin both on the right and the left side of the field. Manual switching is also possible.

The DRILLMAT III is also used to monitor the seeder. The metering shaft and fan speeds are continuously monitored. A fill level sensor indicates low seed levels.

In addition, the DRILLMAT III provides information on seeded areas, area output, covered distance and speed.

## Technology

- High-performance microprocessor technology
- Clearly arranged, resistant membrane keypad
- Solid plastic casing
- Large illuminated LCD display
- The displayed function is marked with an arrow on the screen
- Central plug: easy and uncomplicated connection of sensors and actuators
- Self-test when switching on
- Temperature range -10°C to +70°C
- Sensors and junction box are moulded and therefore resistant against moisture and dirt
- Connection of motorized tramline control
- Also possible for solenoid flaps upon request
- Connection for pre-emergence marker available
- Capacitive fill level sensor (adjustable)

## Advantages

- Easy installation and operation
- Conversion of the tramline width without long set-up times
- Robust and durable technology
- Prevention of seeding errors
- Area counter for precise billing
- Can also be used as a hectare counter on other implements





## PRECIMAT

PRECIMAT is a monitoring device for precision planters with seed counting. Up to 12 seeding units can be monitored with optosensors (optical sensors). It is also possible to shut off up to 12 seeding units. Alternatively, on implements with more than 12 rows, it is also possible not to use any monitoring and instead install up to 18 shutoffs for seeding units. In addition to precision planting, the PRECIMAT can also be used as a hectare counter for all other applications.

### System components

- On-board integrated display/controller (installed in the tractor cab) for entering the required data and monitoring. In the event of a fault, an acoustic and visual alarm is triggered.
- Implement junction box (installed on the seeder frame) with a connecting cable to the on-board integrated display/controller
- Optosensor (installed on the bottom part of the casing of each seeding unit) with a connecting cable to the implement junction box
- Wheel sensor to determine the driven distance
- Cable to the shut-off clutches

### Functions

The falling corn seeds are detected by the optosensor (infra-red barrier). Each seed triggers a pulse in the on-board integrated display/controller, which monitors each row for a predefined target rate. If the deviation from the target rate is more than 15 %, an acoustic and visual alarm is issued. The number of the faulty seeding unit is shown on the display along with the seeds/ha (x 1,000). In addition, a pointing arrow appears above the seeding unit icon. Pre-selection is made with the "Switch on/shut off from the left or right" buttons. The "- button" is used to shut off and the "+ button" for switching on.

The PRECIMAT also determines the following data:

- Total area per task
- Total area per season
- Speed
- Working time
- Area output
- Distance

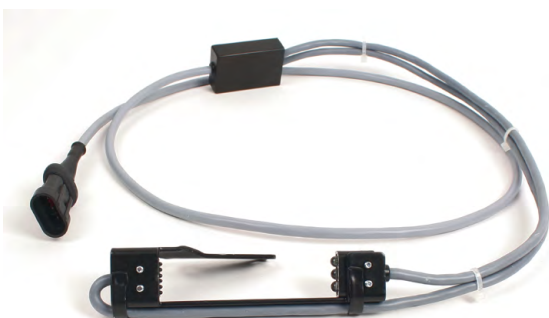

### Advantages

- Inexpensive entry-level solution
- Easy installation and handling
- Monitoring of the seeding rate
- Can also be used as an area counter

**Müller-Elektronik GmbH & Co. KG**

Franz-Kleine-Straße 18 . 33154 Salzkotten . Germany

Tel. +49 5258 9834-0 . Fax +49 5258 9834-90

info@mueller-elektronik.de . www.mueller-elektronik.de

01/2019 . subject to change.

Your local dealer: